

版次	变更内容	审核	日期

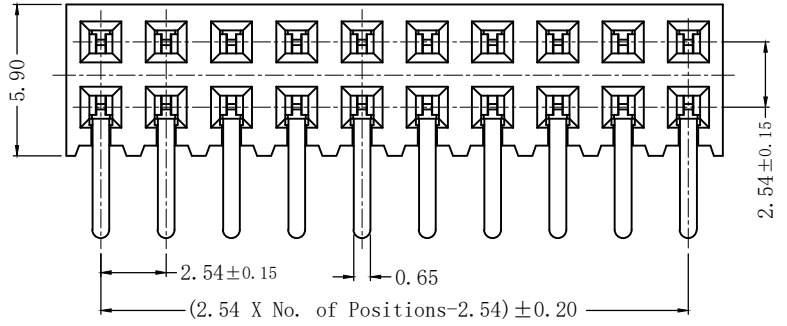

弯曲度: 2*02P ~ 2*20P 0.30 MAX.
 2*21P ~ 2*30P 0.40 MAX.
 2*31P ~ 2*40P 0.50 MAX.

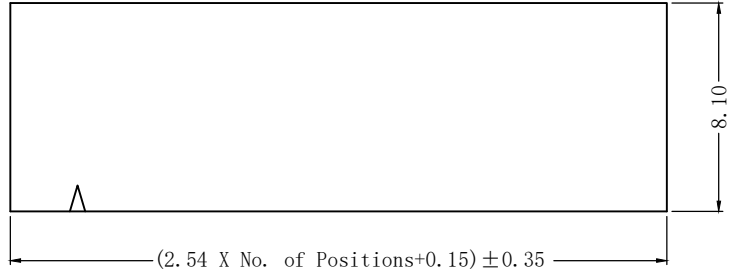
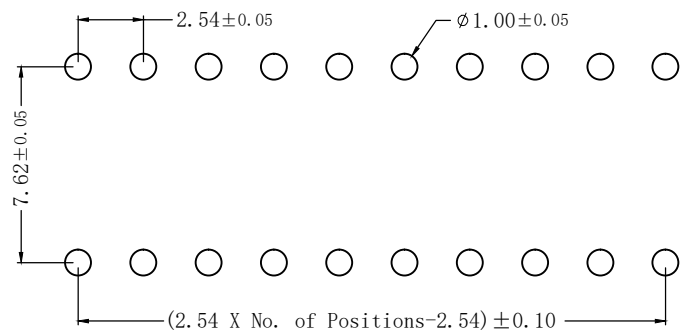

Recommended PCB Layout

204-2*xxP G-A
 单排芯数 01~40P
 脚距 7.62: 7.62mm
 电镀
 G: 镀金Gold Flash
 1G: 镀金1u"
 3G: 镀金3u"
 (镀金可订制)

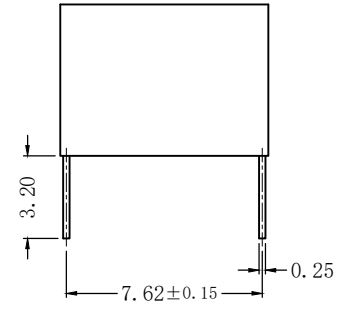

技术参数: SPECIFICATIONS

额定电流 (Current Rating): 3A
 绝缘电阻 (Insulation Resistance): 1000Ω Min.
 接触电阻 (Contact Resistance): 20mΩ Max.
 额定电压 (Dielectric Withstanding Voltage): AC 500V
 工作温度 (Operating Temperature): -40°C ~ +105°C
 最大加工温度 (Max Processing Temp): (230°C for 30~60 seconds)
 (260°C for 10 seconds)
 接触材料 (Contact Material): 磷青铜(Phosphor Bronze), THICKNESS 0.40mm
 塑胶材料 (Insulator Material): 尼龙(Nylon)-9T, UL 94V-0, 颜色: 黑色
 接触电镀 (Contact Plating): 镀金 (Gold plated)
 (电镀规格可根据客户要求来定制)
 Opitonal planting on request.

公差:	版次:	A	上海宗进电子科技有限公司		
	比例:		Shanghai Zong Jin Electron Technology Co.LTD		
. X ±0.35 . XX ±0.25 . XXX ±2° LNLB	单位:	mm	型号:	204-2*xxPG-A	签名
	页码:	1/1	描述:	2.54双排侧插排母	日期
	图号:				绘图:
					确认:
					审核: